



# Installation Instructions

Part No. UCA041FA

## To Suit: Holden/Chevrolet

- Colorado RG 2012+
- Trailblazer 2012+
- Colorado 7 2012+

## Kit Contains:

- 1 x Left upper control arm
- 1 x Right upper control arm
- 2 x Ball joints
- 2 x Nyloc nuts
- 4 x SHCS 8mm bolts & flange nuts
- Sensor brackets
- Brake hose brackets
- Striker pads

**Installation Time:** 1 1/2 to 2 Hours, inc Wheel Alignment

*Professional wheel alignment is required*

1. Safely raise and support vehicle on hoist or jack and stands.
2. Remove front wheels / tyres.
3. Loosen both control arm mounting bolts (2).
4. Ubolt and remove ABS brake wire and brake hose bracket (3).
5. Remove split pin and separate ball joint from upright (1). Use a ball joint breaker / remover tool to release ball joint from taper.
6. Remove both mounting bolts (2) and arm from vehicle.
7. Install supplied ball joint to each upper control arm, tension each M8 bolt to 27N/m using supplied spring washer under bolt head and flange nut to the underside of the arm. Apply a small amount of high strength thread locker during assembly.
8. Assemble sensor brackets, striker pads and brake hose brackets. Install new Pro-Forge Control Arm into vehicle, insert mounting bolts and existing mounting hardware, but DO NOT tighten at this stage.
9. Connect ball joint to upright and tension to 70N/m.
10. Re-install ABS brake wire and brake hose to arm. Repeat procedure for both sides of the vehicle.
11. Re-install wheels / tyres, lower vehicle to the ground.
12. With the vehicle on flat level ground at final ride height, tighten the control arm mounting bolt (2) and tension to 115N/m (85 ft/lb).
13. Check all fasteners and ensure clearance around all components.

Fig 1

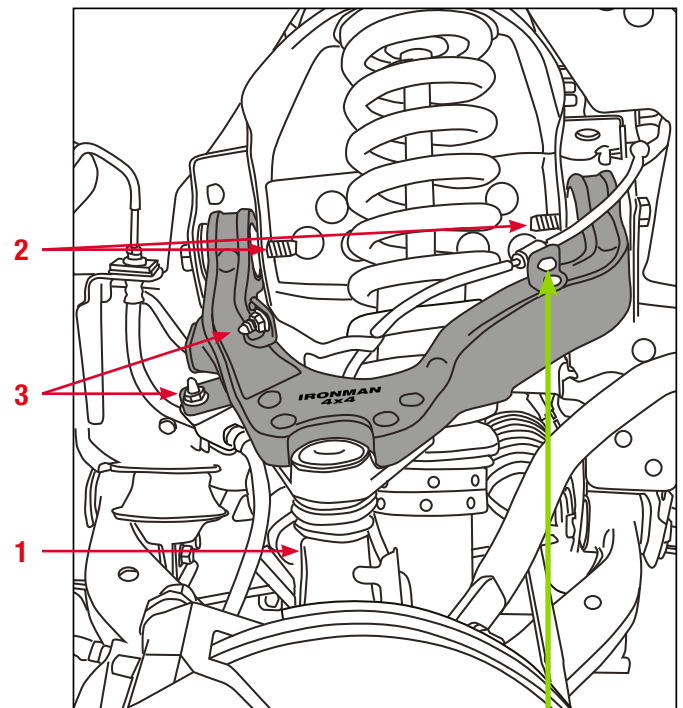

**Note:** ABS wire MUST be clipped into bracket in the orientation as illustrated



**Installation  
Instructions**  
Part No. UCA041FA

## **Wheel Alignment**

A strong understanding of wheel alignment procedure is required. Ironman 4x4 recommends wheel alignment be carried out by a trained alignment professional only.

Ironman 4x4 Pro-Forge Upper Control Arms will significantly change the wheel alignment settings by comparison to the OEM arm, for the purpose of correcting alignment after raising ride height.

Adjustments to Camber, Caster and Toe will be required.

Using the lower control arm eccentric cams, in most instances set alignment within the following range, or according to OEM specification.

Caster: + 3.5° to + 4.0°

Camber: + 0.50° to - 0.50°

Toe: + 1mm to - 0.5mm

A high caster setting will aid in providing additional clearance to mud flaps when fitting larger tyres.

Always set wheel alignment settings in relation to tyre wear for each individual vehicle.

---

***Warranty will be voided by damage or failure caused by incorrect procedure.***

***Before proceeding to install Pro-Forge Upper Control Arms, please fully read instructions and ensure that necessary tools are on hand.***

***Professional Wheel Alignment Required.***

***Always wear personal safety protection ie. safety glasses and gloves to prevent injury.***